

**SECURE & PROTECTED  
CABLE CONTAINMENT  
FOR DATA CENTRES**

**01384 233445**

sales@armorduct.com

**DataLine EMT**



**The most versatile  
EMT solutions**

 **Armorduct**

## Product Specification

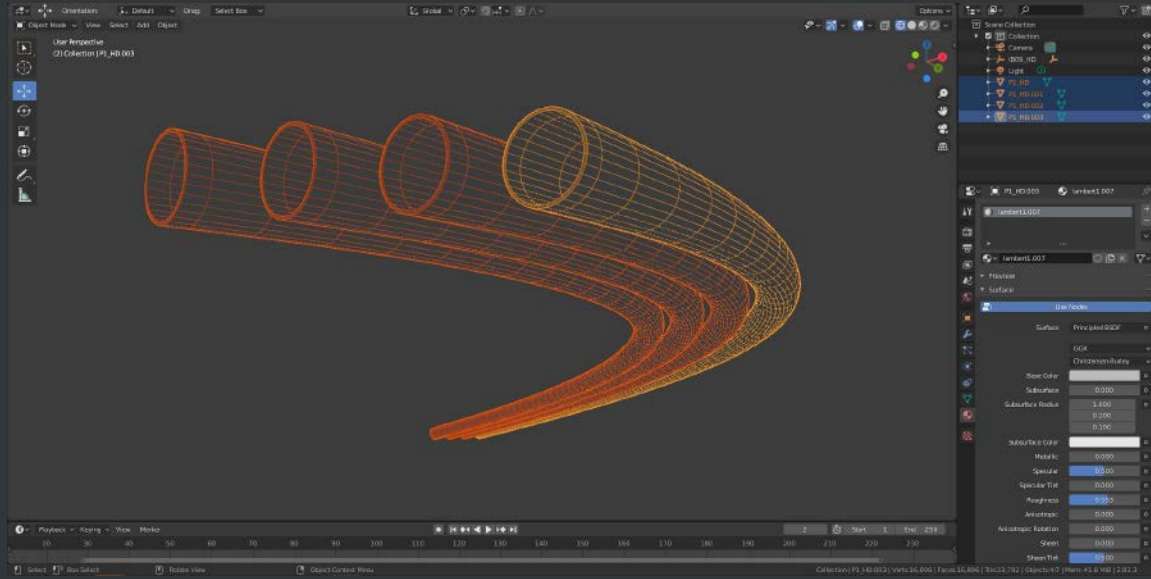

## System Design

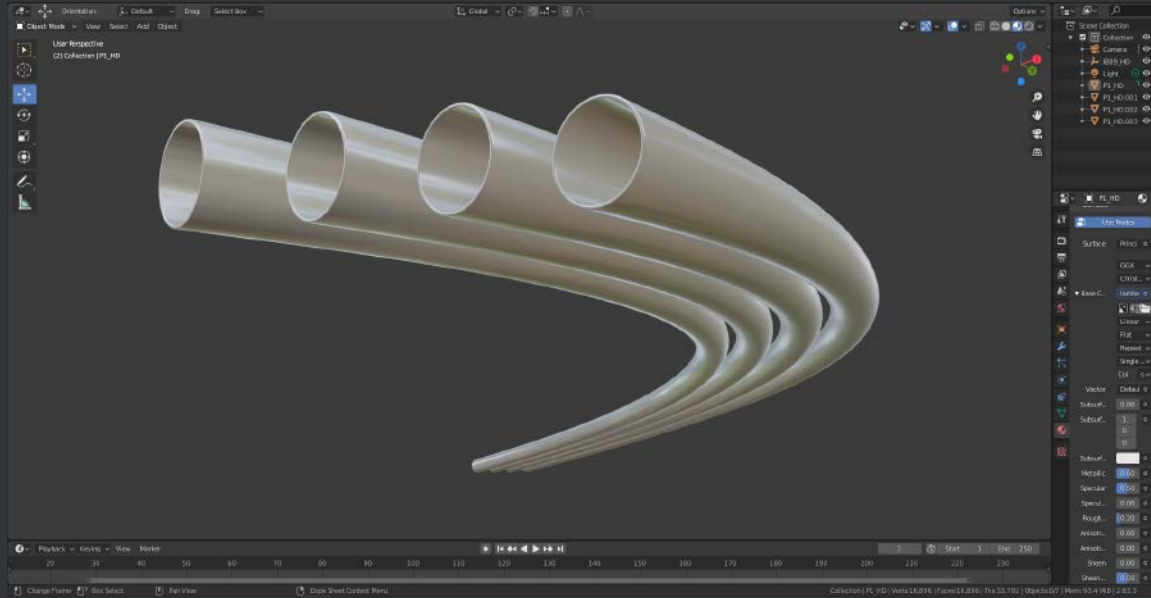

## Project Delivery



### VERSATILE

- End-to-end fibre optic cable containment in single or multiple pipe configurations
- Point of entry through to server environment, colour-coded as required
- Internal, external, floor, ceiling and wall systems
- 110mm or 50mm pipe diameters with custom bend and radius options
- Access solutions for cable pulling, routing, inspection and maintenance

### PROTECTED

- Robust thick wall steel pipe for uncompromised protection of data cables
- Seam welded, flow-coated smooth internal finish prevents cables snagging
- E90 fire resistant system protection
- Pipe wall density provides EMC protection against interferences like radio, lightning and static electricity

### SECURE

- Tamperproof and segregation solutions for restricted access and co-location installations
- Fully-secured threshold navigation for internal and external requirements

### QUALITY

- Approved to BS EN 61386-25 for cable management conduit systems
- Factory manufactured under ISO 9001 / ISO 14001 certification standards
- Industry standard bracketry and support solutions

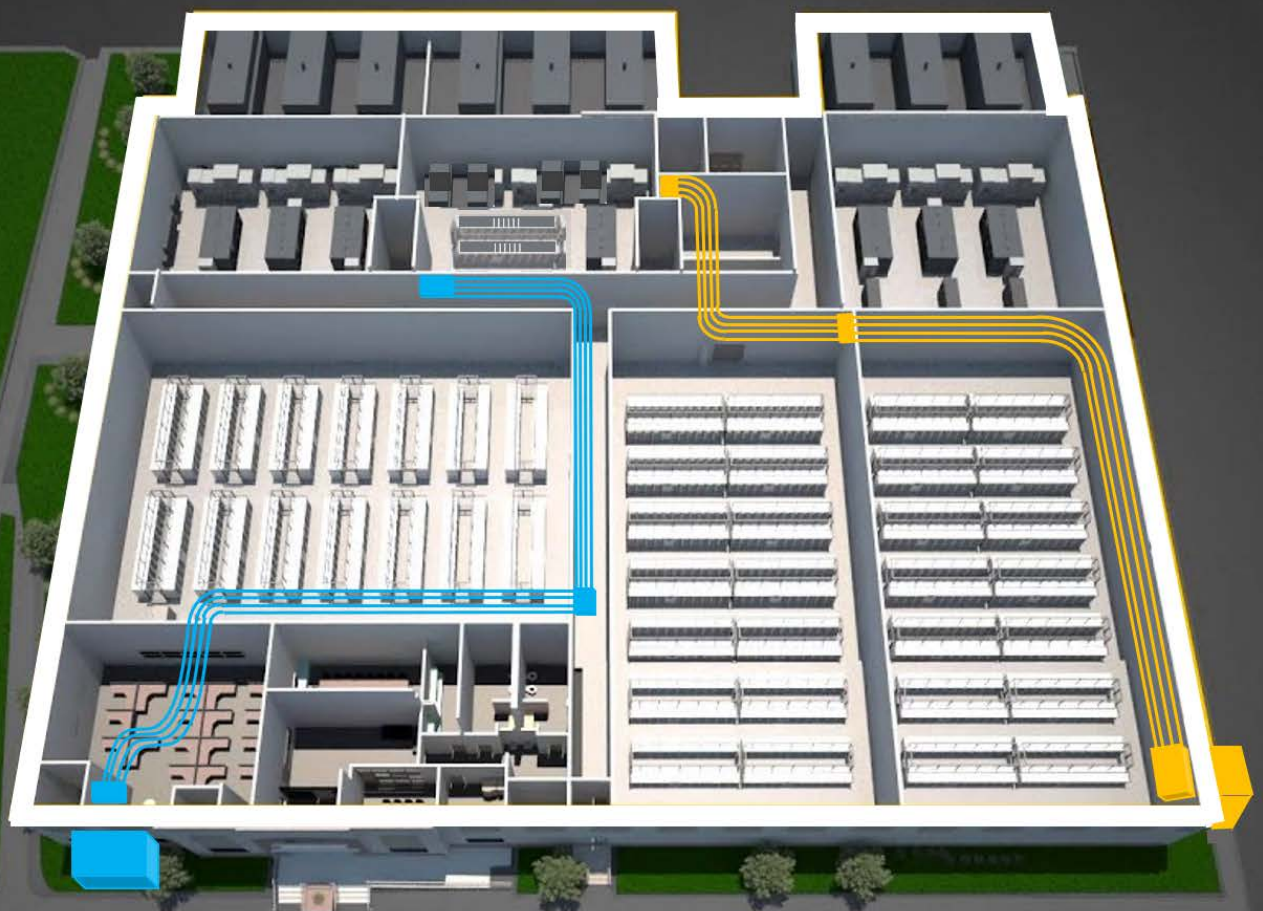

# Pipes & Bends

END-TO-END SYSTEM DESIGN TO CLIENT SPECIFICATION

- Flow-coated, hot-dipped galvanised steel for smooth interior surfaces
  - 50mm or 110mm diameters
  - Standard and custom lengths
- Single, multiple and colour-coded
  - Custom bends and radiuses

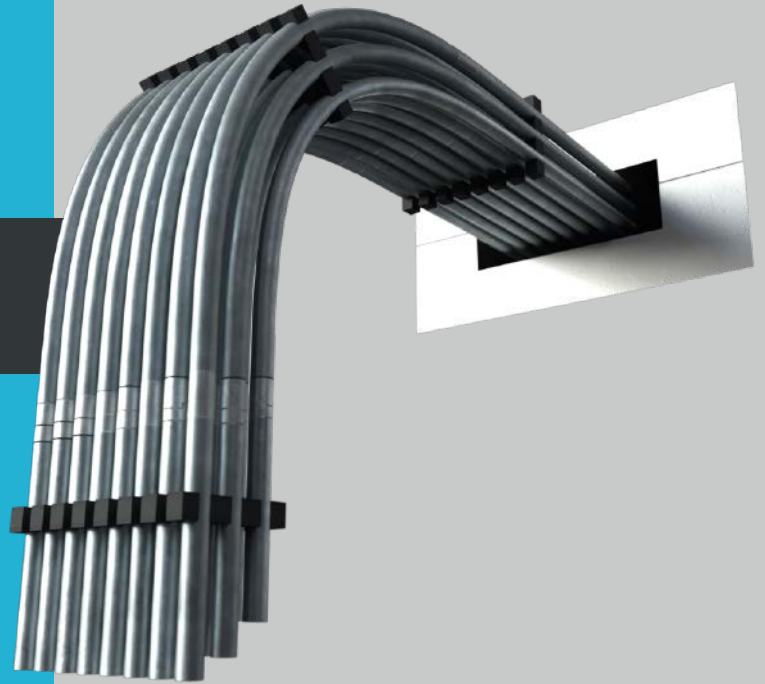

	50mm	110mm
STRAIGHT	EMT50	EMT110
45° BEND (at radius 'R')	EMT50/45R900	EMT110/45R900
90° BEND (at radius 'R')	EMT50/90R985	EMT110/90R985

Supplied in 3 metre lengths as standard

**50mm:** Inner Diameter: 47mm Outer Diameter: 50mm  
**110mm:** Inner Diameter: 104mm Inner Diameter: 110mm

## Slip Loader

- CABLE INSERTION



50mm EMT50/SL  
 110mm EMT110/SL

## Reducer

- INTER-SYSTEM COMPATIBILITY



EMT/RED/63-50

## Couplers

• PIPE-TO-PIPE JOINTS



	straight	15°	30°	45°
50mm	EMT50/COU	EMT50/COU15	EMT50/COU30	EMT50/COU45
110mm	EMT110/COU	EMT110/COU15	EMT110/COU30	EMT110/COU45

## Transit Blocks

• STRUCTURAL INTEGRITY FOR MULTI-PIPE SYSTEMS

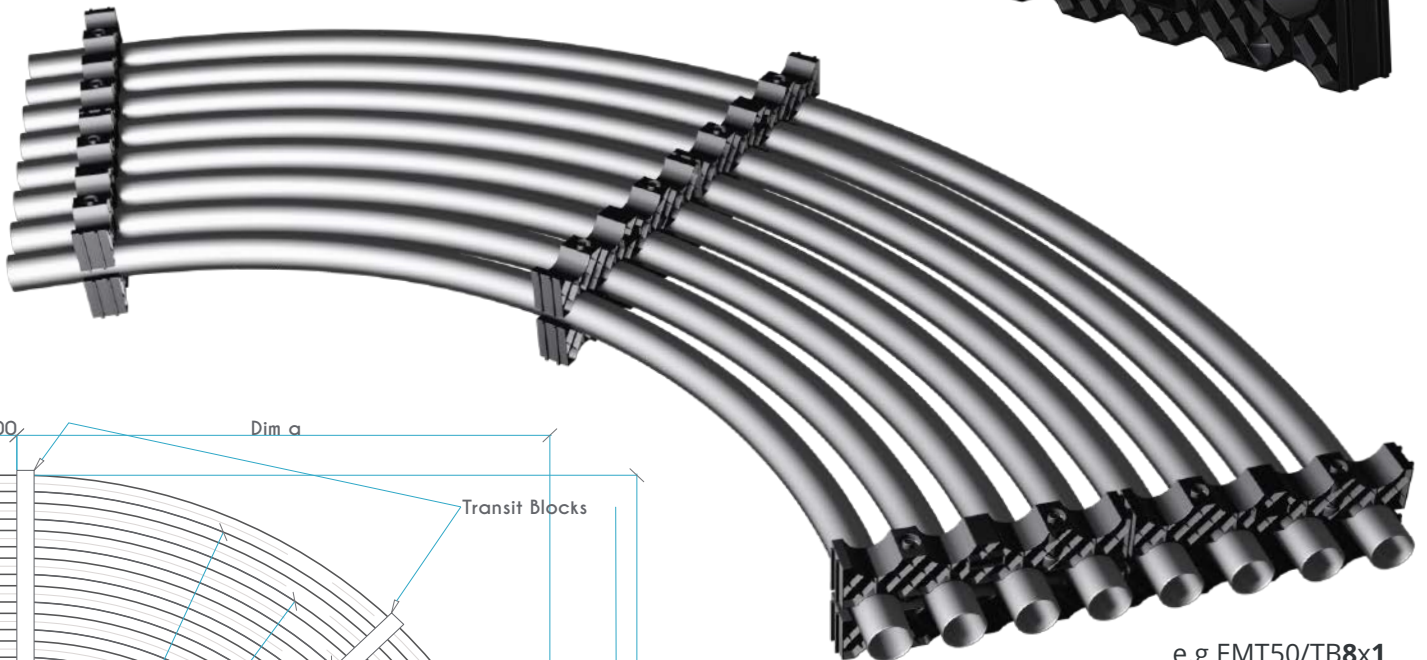
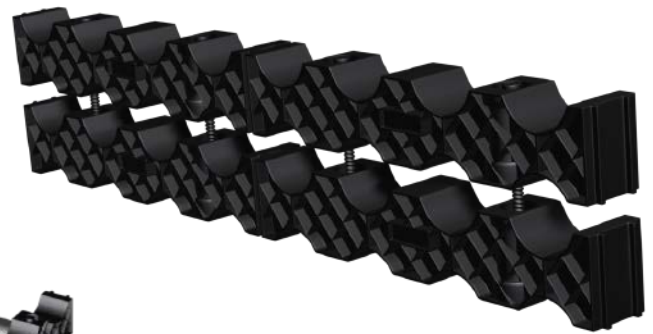

e.g EMT50/TB8x1

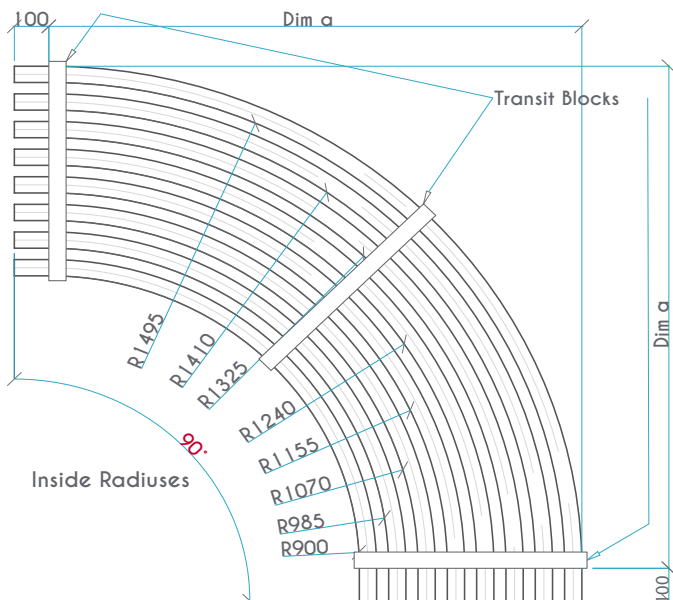

50mm EMT50/TB H x V

110mm EMT110/TB H x V

Please state **Horizontal** then **Vertical**

# Inspection Boxes

For Installation, routing,  
maintenance and inspection

COMPLETE SYSTEM DESIGN TO  
CLIENT SPECIFICATION

- Secure system access
- 50mm or 110mm diameters
- Tamper-proof / lockable & colour-coded solutions for co-location sites
- Single or multiple EMT system configurations (user specified)

\* Please state horizontal then vertical when ordering

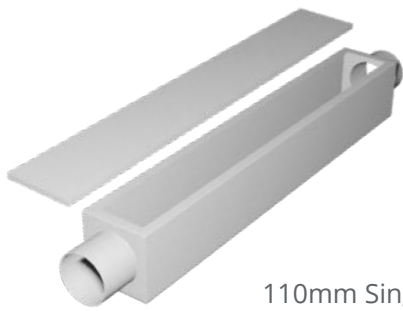

EMT110/IB1x1

110mm Single Inspection Box Straight



EMT110/IB1x1/R90

110mm Single Inspection Box 90°



EMT110/IB4x1/F90

110mm 4x1 Flat Inspection Box 90°

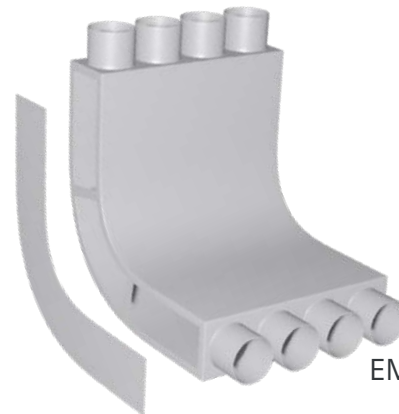

EMT110/IB4x1/SMR90

110mm 4x1 Smooth Riser 90°



EMT110/IB1x4/FR90S

110mm Sharp Riser Small 90°



EMT110/IB  
4x1/FR90L

110mm Sharp Riser Large 90°

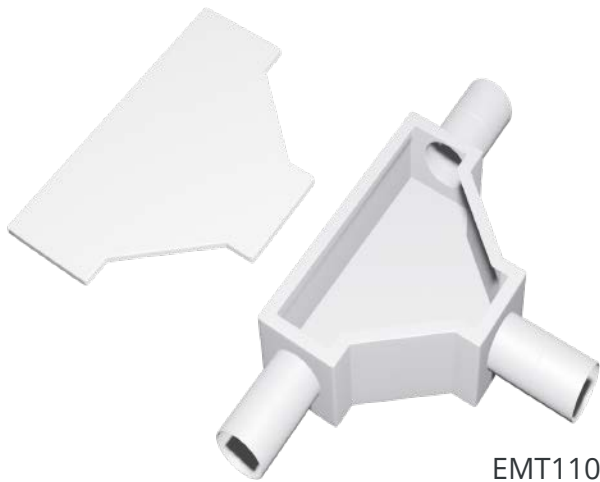

EMT110/IBTEE

110mm Inspection Tee

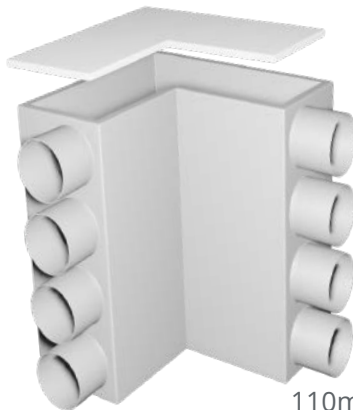

EMT110/IB1x4/S90

110mm 1x4 Sharp Bend 90°



EMT110/IB2x3

110mm 2x3 Inspection Box Straight



**POWDER  
COATED**  
TO CUSTOMER  
SPECIFICATION

COLOUR CODED



EMT110/IB4x4/90

110mm 4x4 Inspection Box 90°



EMT110/IB4x4-2x8/90

110mm 4x4 to 2x8 Inspection Box 90°

Wall Plates  
Floor Plates  
Joiners

MULTIPLE CONFIGURATION OPTIONS  
TO CLIENT SPECIFICATION



EMT110/J4X1

110mm 4X1 Joiner

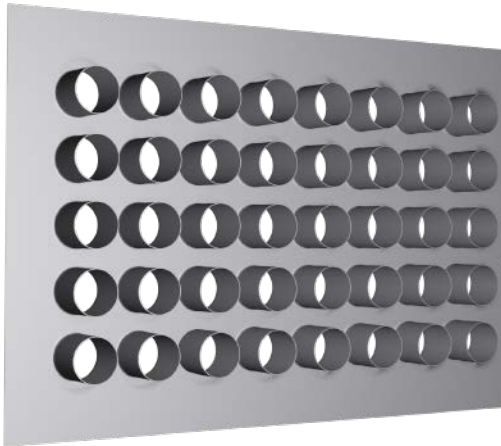

EMT110/WP8X5

110mm 8x5 Wall Plate

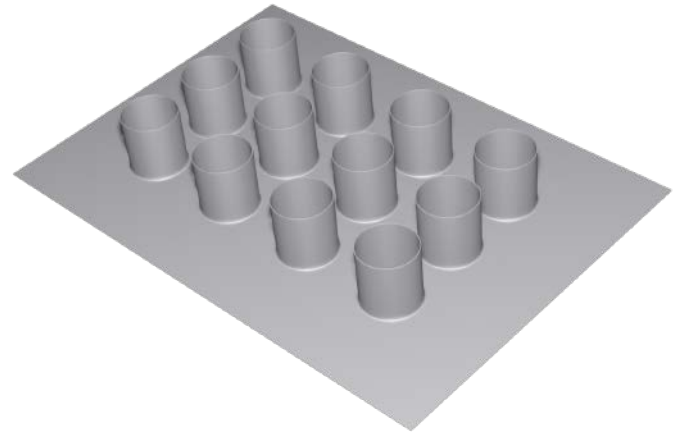

EMT110/FP4X3

110mm 4x3 Floor Plate

## Point of Entry Boxes

- ROBUST, SECURE-ACCESS, EXTERNAL INSPECTION CABINETS



EMT/POEBOX

## Duct Plugs

- CORROSION-PROOF, WATER-TIGHT, AIR-TIGHT
- DEBRIS & ANIMAL SECURE
- RE-USABLE & REMOVEABLE



DUCT PLUG